

# A-Frame Series

- Electric 3 phase powered unit
- 90m capacity hose reel
- Water break tank
- Trolley or Skid mounted



Model	A-Frame Series
Pressure and Flow	Pressure up to 415 bar (26 l/min) Flow to 45 l/min (275 bar) (see reverse for options)
Pump	Harben® 'P' type radial piston pump
Motor	400v/3ph/50Hz (440-480v/3ph/60Hz) IP55 with other options available on request
Water Tank	Break tank complete with ball valve
Frame	Lightweight box section steel
Hose Reel	90m (300ft) capacity manual live centre hose reel
Dimensions	Skid version: 1300 mm long x 1090 mm wide x 1540 mm high *
Weight	Dry weight from 300-800 Kgs
Build Options	Trolley or Skid mounted, pressure control valves, anodised crankcase for aggressive fluids, ATEX version

\* All weights and dimensions are approximate.

For Accessories please visit: <http://www.flowplant.com/drain-jettors/accessories/>

## Flowplant Group Ltd

Gemini House, Brunel Road,  
Churchfields Industrial Estate,  
Salisbury, Wiltshire. SP2 7PU  
United Kingdom

t: +44 (0) 1722 325 424  
f: +44 (0) 1722 411 329  
e: sales@flowplant.co.uk

- High Pressure
- Cleaner Solutions

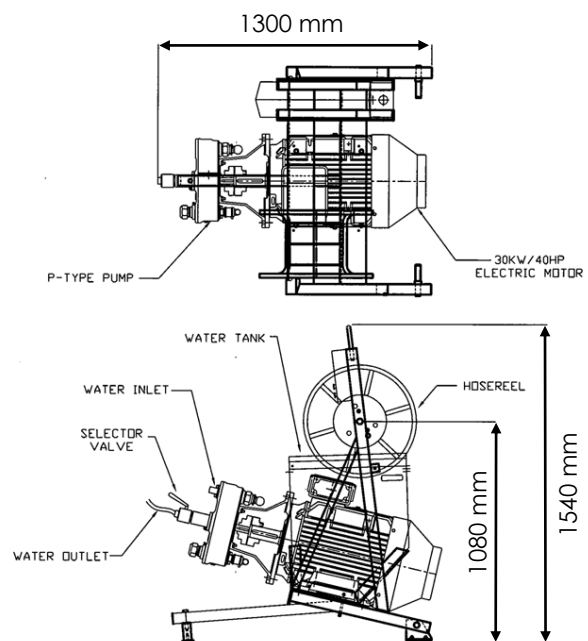
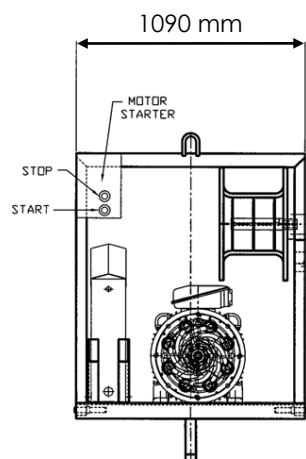

# A-Frame Series

## PUMP OUTPUTS

The Harben® P type pump can be operated at up to 1300 rpm when used with inverter drives. The tables below show the performance in l/min that can be expected when operating on 50 Hz and 60 Hz electrical supplies with a 6 pole motor at maximum working pressure.

### 50 Hz supply

P Pump Model		415 Bar				350 Bar				275 Bar			
		3x18	4x18	6x18	8x18	3x20	4x20	6x20	8x20	3x22	4x22	6x22	8x22
Motor Power kW / 6 pole / 50 Hz / 975 rpm *	11 kW	9.2	12.6			12.1				17.8			
	15 kW			18.9			17				23.3		
	18.5 kW							25.3					
	22 kW				26.4				33.9				
	30 kW											36	45.5

\* All performances are approximate.

### 60 Hz supply

P Pump Model		415 Bar				350 Bar				275 Bar			
		3x18	4x18	6x18	8x18	3x20	4x20	6x20	8x20	3x22	4x22	6x22	8x22
Motor Power kW / 6 pole / 50 Hz / 975 rpm *	11 kW	11.1	15.2			14.6							
	15 kW						21				21.5		
	18.5 kW			22.8								28	
	22 kW				31.9				30.5				
	30 kW									40.9			43.4

### Flowplant Group Ltd

Gemini House, Brunel Road,  
Churchfields Industrial Estate,  
Salisbury, Wiltshire. SP2 7PU  
United Kingdom

t: +44 (0)1722 325 424  
f: +44 (0)1722 411 329  
e: sales@flowplant.co.uk

- High Pressure
- Cleaner Solutions

