

# Operation & Maintenance Manual

*Original Instructions*

---

## **UNIT DTK 500 TRAILER MANUAL AND RADIO (004-416, 004-422)**

Section 1	Contents & Introduction
Section 2	Scope of Supply
Section 3	Technical Data
Section 4	Operation
Section 5	Routine Maintenance
Section 6	Fault Finding
Section 7	Pump
Section 8	Circuit Diagrams
Section 9	Diesel Engine
Section 10	Parts list / Spares / Auxiliary components
Section 11	Service Documents
Section 12	Warranty & Certification

**Operation & Maintenance Manual for:**

**UNIT:** DTK 500 TRAILER  
 004-416 4012 RADIO  
 004-422 4012 MANUAL  
**ISSUE DATE:** 07/2020

**AMENDMENTS**

<b>Change</b>	<b>Changes</b>	<b>Date</b>	<b>Signature</b>
1	INITIAL RELEASE	07/20	JHGS
2	SRV COMMENT ADDED	11/20	JHGS
3	IMPORTANT MESSAGES ADDED	01/21	JHGS
4	ADDED INSTRUCTION TO RE GEN PROCESS, ADDED ADDITION OF MANUAL SELECTOR TO OPERATION SECTION	03/21	SAS

# 1. Contents & Introduction

## 1.1. Contents

<b>1. CONTENTS &amp; INTRODUCTION .....</b>	<b>3</b>
1.1. CONTENTS.....	3
1.2. INTRODUCTION.....	6
1.3. SCOPE OF THIS MANUAL .....	7
1.4. THE TRAILER .....	7
1.5. COMPOSITION OF THIS MANUAL .....	8
<b>2. SCOPE OF SUPPLY.....</b>	<b>9</b>
2.1. SCOPE OF SUPPLY .....	9
2.2. PUMP ASSEMBLY .....	9
2.3. DETAILED DRAWINGS.....	10
<b>3. TECHNICAL DATA.....</b>	<b>11</b>
3.1. TECHNICAL DATA .....	11
3.1.1. PUMP DATA.....	11
3.1.2. MAIN COMPONENTS .....	12
3.1.3. ANCILLARIES.....	12
3.1.4. SERVICES REQUIRED .....	12
3.2. TECHNICAL DESCRIPTION .....	13
3.2.1. PRIMARY COMPONENTS.....	13
3.2.2. ENGINE MONITORING.....	13
3.3. INSTALLATION DETAILS.....	13
<b>4. OPERATION.....</b>	<b>14</b>
4.1. OPERATING CONDITIONS .....	14
4.2. DAILY CHECKS .....	14
4.3. PRE-START CHECKS & PROCEDURES .....	14
4.4. STARTING THE ENGINE AND SETTING THE OPERATING PRESSURE .....	15
4.4.1. OPERATING STARTING PROCEDURE.....	15
4.4.2. CHECKING THE OPERATING PRESSURE WITH A NOZZLE FITTED.....	16
4.4.3. DPF REGENERATION.....	17

- 4.5. REMOTE OPERATION..... 21**
- 4.5.1. STARTING THE ENGINE ..... 21
- 4.6. RAPID SHUTDOWN ..... 22**
- 4.7. AUTOMATIC SHUTDOWN ..... 22**
- 4.8. HARBEN® JUMP JET ..... 23**
- 4.9. HOSE REEL WINDING AND UNWINDING ..... 23**
- 4.10. FROST PRECAUTIONS..... 25**
- 4.10.1. TO ANTI-FREEZE THE MACHINE WITH AN ANTIFREEZE TANK: ..... 25
- 4.10.2. TO DE-ANTIFREEZE THE MACHINE: ..... 27
- 4.10.3. TO ANTIFREEZE WITHOUT AN ANTIFREEZE TANK:..... 28
- 4.10.4. TO DE-ANTIFREEZE:..... 28
- 5. ROUTINE MAINTENANCE ..... 29**
- 5.1. MAINTENANCE PROCEDURES..... 29
- 5.2. DAILY MAINTENANCE ..... 30
- 5.3. P-PUMP LUBRICATING OIL..... 31
- 5.4. P-PUMP BURST DISCS ..... 32
- 6. FAULT FINDING..... 33**
- 6.1. SHUTDOWN PROBLEMS ..... 33
- 6.2. EQUIPMENT FAULT FINDING..... 34
- 6.3. P-PUMP FAULT FINDING ..... 35
- 6.4. SELECTOR FAULT FINDING (SEE SECTION 8)..... 37
- 7. PUMP..... 38**
- 8. CIRCUIT DIAGRAMS..... 39**
- 8.1. HYDRAULIC CIRCUIT..... 40
- 8.2. WATER CIRCUIT ..... 41
- 9. DIESEL ENGINE..... 42**
- 10. PARTS LISTS / SPARES..... 43**
- 10.1. INTRODUCTION..... 43
- 10.2. ORDERING SPARE PARTS..... 43
- 10.3. PARTS LIST ..... 44

<b><u>11. SERVICE DOCUMENTS.....</u></b>	<b><u>54</u></b>
11.1. SERVICE CHECKLIST .....	54
11.2. SERVICE LOGBOOK .....	55
<b><u>12. WARRANTY .....</u></b>	<b><u>57</u></b>
12.1. WARRANTY OF NEW PRODUCTS: .....	57
12.2. WARRANTY OF SPARE PARTS: .....	57
12.3. LIMITATIONS OF WARRANTY:.....	58

## 1.2. Introduction

Please ensure that you read this Operation & Maintenance Manual in conjunction with the Health & Safety Manual before operation.

Within this manual the health and safety risks are highlighted with  and you are required to read the relevant section in the Health & Safety Manual.

### Notices

Carefully read the notices of this manual because they give important information concerning safe installation, use and maintenance; familiarise yourself with the workings of the machine in order to rapidly switch it off and eliminate pressure.

This manual is an integral and essential part of the product; it must be consigned to the user in order to ensure the training/information for personnel.

The manufacturer does not assume responsibility for damage caused to persons, property or to the machine, in the case of improper use. Carefully preserve this manual for any further consultation.

Identify the model of your machine by reading the details on the identification plate. Upon delivery, inspect the machine / accessories for any damage, which may occur during transport.

**IMPORTANT:** Always follow the recommended operating procedures; do not misuse the equipment as this could result in injury or mechanical breakdown!

### 1.3. Scope of this Manual

This manual provides operation and maintenance instructions for the trailer. Where the unit has been fitted with proprietary components, details of these are also included in this manual.

This manual is compiled to match the Scope of Supply detailed in Section 2. All specifications, descriptions and parts lists refer only to the components in the version of the unit detailed in this scope of supply.

Maintenance instructions included in this manual include:

- Routine maintenance to be carried out at specific times.
- Maintenance of the high-pressure pump.

Repairs to the pump crankcase are not considered maintenance operations as these should be undertaken only by FLOWPLANT, their approved agents, or at least competent automotive engineers.

### 1.4. The Trailer

The Trailer is a highly versatile mobile high-pressure water jetting unit, which offers the benefits of proven power pack and pump performance with a comprehensive range of accessories.

It is plated at 1600 kgs and it has a maximum operational weight of 1500 kgs when filled with water to the maximum level allowed by the inlet float valve.

The options fitted to and the accessories supplied with this Trailer are detailed in Scope of Supply in Section 2

## **1.5. Composition of this Manual**

This manual comprises the following further sections:

### **Section 2    Scope of Supply**

This section defines the scope of supply of the equipment in compliance with the sales order.

### **Section 3    Technical Data**

This section contains technical information about the unit.

### **Section 4    Operation**

This section describes the recommended operating procedures for the unit.

### **Section 5    Routine Maintenance**

This section details recommended routine maintenance requirements for the pump and unit.

### **Section 6    Fault Finding**

Fault diagnosis tables for the pump, engine and ancillaries.

### **Section 7    Pump**

Details of the pump and gearbox assembly.

### **Section 8    Circuit diagrams/Electrical Details**

This section includes the Hydraulic, Water and Electrical circuits including engine controller & wiring loom.

### **Section 9    Diesel Engine**

This section provides part details of the Kubota diesel engines.

### **Section 10   Parts list / Spares / Auxiliary components**

How to identify and order spares / auxiliary components.

### **Section 11   Service Documents**

Service logbook and checklist.

### **Section 12   Warranty & Certification**



## 2. Scope of Supply

### 2.1. Scope of Supply

Unit:	DTK 500 Trailer
Machine Build Code:	004416 4012 RADIO 004422 4012 MANUAL

### 2.2. Pump Assembly

The General Arrangement drawing No. 004-416 defines the components of the Trailer assembly as follows:

The pump is driven by an industrial diesel engine.

The engine drives the pump via a reduction gearbox which reduces the pump rpm down to the correct shaft speed.

Water is fed through the inlet hose reel from a mains supply into a plastic water storage tank; the tank supplies the pump with a positive head of pressure via a Hypro 80 mesh inline strainer that filters the water to approximately 177 microns.

***(Do not fill the water tank directly, always use the inlet hose reel (in order to comply with Local Water Authority Regulations).***

The 'P' Type 8 22 radial piston high-pressure diaphragm pump is driven by a Kubota 1803 3cyl industrial diesel engine through a 2.0:1 reduction gearbox.

The pump's selector can direct the water at high-pressure to a hydraulically driven hose reel or at low pressure 'dumped' back to tank.

The systems are protected from over pressurisation by a safety relief valve.

The engine and system pressure can be monitored at the control panel situated at the rear of the trailer.

### **2.3. Detailed Drawings**

Detailed drawings and parts lists for the above components are provided as follows:

The Pump is detailed in Section 7.

Details of other parts and assemblies are included at Section 10.

## 3. Technical Data

### 3.1. Technical data

#### 3.1.1. Pump data

	P Type 8 22
Pump width	405 mm
Pump length	385 mm
Inlet	28.6 mm dia
Outlet	G1/2" (1/2" BSP)
Shaft dia	30 mm
Shaft length	65 mm
No. of cylinders	8
Power rating (nominal)	26 kW
Piston diameters	22 mm
Shaft speed	1250 rpm
Maximum pressure	275 bar (4000 psi)
Nominal Flow rate	55 lpm (12 Gpm)
Crankcase lubrication	Fully immersed
Oil capacity (litres)	5.0 litres
Weight (kg)	80 kg
Recommended crankcase oil	Shell Morlina 150 or Tellus 150 (see
Max inlet pressure	0.5 bar (5.0 metre head)
Max inlet temp.	25°C

### 3.1.2. Main Components

#### 004-416 / 004-422

Engine	Kubota D1803-CRT-E5B-UEU
Gearbox	020143 – Harben Reduction 2.00:1

---

### 3.1.3. Ancillaries

Water tank	500 Litres Nominal Capacity
Supply filter	N05105 Hypro Line Strainer / 80 Micro Mesh
Monitoring & Control	Murphys MPC-20
Pressure Control and Safety	Pressure Transmitter 0-300 bar

---

### 3.1.4. Services required

Mains water supply	Positive head capable of delivering greater than 60 lpm. <i>Note: Water pH value of 5 to 9 is recommended.</i>
--------------------	---

## 3.2. Technical Description

### 3.2.1. Primary Components

The primary components of the trailer are as follows:

- A prime mover in the form of an industrial diesel engine which drives a high-pressure pump.
- The pump is capable of producing high-pressure water *Note: See above or section 7 for performance options.*
- A hydraulic driven hose reel with high-pressure hose with either a nozzle or gun attachment to deliver the high-pressure water to the work application.
- Plastic Polyethylene water tank, acting as a reservoir, also ensuring the water is settled and non-turbulent, discharging a smooth uninterrupted supply, with a positive head of pressure to the inlet, maximising the full potential of the pump.
- The selector valve either directs high pressure water to the hose (valve open) or diverts water back to the tank (dump).
- The front panel fascia which includes the control panel, selector, jump jet valve, and the emergency stop button.
- A Hypro 80 micro mesh inline strainer is fitted to the suction line between the tanks and the pump inlet.

*Note: This is a critical component which ensures that no contaminants are drawn into the pump inlet. This filter must be inspected and cleaned daily, if it becomes blocked it could severely damage the pump*

### 3.2.2. Engine Monitoring

Engine oil pressure and hours run are monitored on the control panel.

## 3.3. Installation details

Installation Drawing Nos. 004-416 provides overall dimensions.

## 4. Operation

### 4.1. Operating Conditions

Operators of water jetting equipment should be fully conversant with the 'WJA Code of Practice for the use of high-pressure water jetting equipment', hereafter referred to as 'The Code of Practice'. A copy of The Code of Practice is available upon request.

Please ensure that you read this Operation & Maintenance Manual in conjunction with the Health & Safety Manual before operation.

Within this manual the health and safety risks are highlighted with  and you are required to read the relevant section in the Health & Safety Manual.



### 4.2. Daily Checks

Refer to Section 5



**SAFETY RELIEF VALVES MUST BE RECALIBRATED EVERY 6 MONTHS**

### 4.3. Pre-start Checks & Procedures

1. In cold weather check that machine is not frozen before starting (see Antifreeze section). Only operate the machine in a well-ventilated area. 
2. Ensure the towing vehicle and trailer hand brakes are applied.
3. Connect the water supply to the inlet hose reel (NOTE: in order to comply with water authority byelaws never fill the tank by putting a hose directly inside). The water will fill the tank via the float valve which ensures the correct tank level is maintained and the tanks are not overfilled.  
 Overfilling the tanks will overload the trailer axles and could make it dangerous.
4. Feed off the hose reel approximately 30 metres of high-pressure hose. **Do not fit the nozzle or gun at this point!**



At any time during the starting procedure, or during normal jetting operations, an emergency shutdown can be achieved by switching off the engine with the key or pressing the E/Stop button.

Fig. 4.1 Estop on control panel. Twist to release

## 4.4. Starting the Engine and Setting the Operating Pressure









With two people, one at the pump set and one in charge of the nozzle or gun.

### Tank water level

Ensure you have an adequate water supply and that the water tank is filled to the ball valve shut off level.

**NOTE:** Do NOT allow unfiltered water into the pump

### 4.4.1. Operating Starting procedure

1. Ensure selector valve is in the dump  position.
2. Ensure the open ended, high pressure hose is in a safe position, preferable within sight of the operator at the control panel.
3. Using the rocker switch marked Power, energise the Control Panel.
4. Enter the 4 digit PIN using the  &  Arrows and  buttons on the controller.
5. Momentarily press the Green Button on the Control Panel to start the Engine. The Engine will automatically start and hold at Idle Speed.
6. Water should now be circulating through the pump and be diverted back to the tank. Bleed the pump if necessary, using the bleed screws on the front of the pump (refer to Section 7). Allow the engine 5 minutes to warm up.
7.  To divert water to the high-pressure hose, press Spray Button on the control panel  or if using manual machine use manual selector.
8. Speed / Pressure can be adjusted using RPM+  and RPM- .
9. To shut the system down, reduce the RPM to Idle and turn off the water. Switch the Engine off by momentarily pressing the Red button. The Engine will shut down safely. Use the rocker switch to de energise the control panel. The system is now safely off.
10. In Emergency Situations punch the emergency stop button.

#### 4.4.2. Checking the Operating Pressure with a Nozzle Fitted

1. Fit the correctly sized nozzle to the high-pressure hose.
2. Ensure the nozzle is in a safe position placed inside the pipe to be cleaned and preferably within sight of the operator at the control panel.
3. Start engine.
4. ⚠ Move the selector valve to the high-pressure position or use the water on off button.
5. Observe the pressure displayed on the control panel and note the pressure reading. Increase engine speed and pressure until the nozzle travels up the pipe
6. Clean short runs at a time.
7. When finished, reduce the speed of the engine.
8. Move the valve to the 'dump' position.
9. Switch the engine off.



*NOTE: Operating the machine with the Jump Jet system turned off can increase the water pressure at the de-silting nozzle by up to 100%. Only do this when you know there is no risk of damage to in-situ*

**If the pressure is significantly lower than expected, turn the unit off and replace the nozzle with a new one as it may be worn.**



### 4.4.3. DPF Regeneration

Periodically the Engine will need to perform a DOC Regeneration Cycle.

**⚠ Ensure the Unit is parked up with the handbrake applied, in a non-combustible environment. Ensure the Unit is full of water, and on DUMP. As this process is noisy and can take time, it is recommended that it is not undertaken at night.**

- 1) The Unit will indicate on the Control Panel when a Regeneration is required by showing the below pop up. This is cleared by pressing enter.

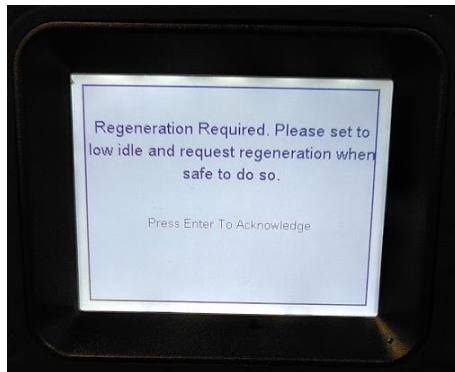

- 2) A slowly flashing symbol shown below continually advises that a Regeneration is a required.



- 3) This requirement for a Regeneration can be confirmed by cycling through to the information screen shown below. A “DPF Level” of 2 or greater needs attention.

Actual RPM	Target RPM	Engine Battery	Run Hours
1000	1000	14.2 volts	13.10 Hrs
Engine Status	Status Time	Remote	Water
Running Loaded	00:00:00	REMOTE DISABLED	Off
Time	Unit pressure	Engine Temp	DPF Level
08:59:21 AM Date 27 Jul 20	0 bar	33.0 °C	2

- 4) Apply both the Park and Neutral Toggle Switches to the “on” position.

- 5) Start machine on idle with the water returning to tank.
- 6) Enter the Engineers pages on the Control Panel by selecting.  
Input the Password to gain access. 1111.



- 7) Select the “Engine Settings” option within the menu by scrolling and pressing enter.

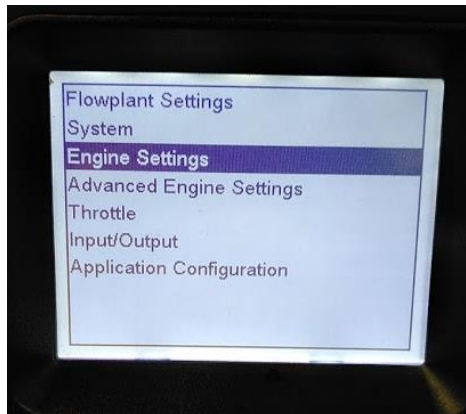

- 8) In the next screen select “Tier 4” within the menu by scrolling and pressing enter.

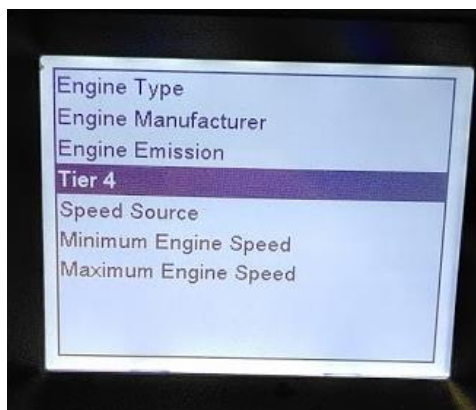

- 9) After this selection, you will then need to select “Request a Regen”. Press enter to choose this option. You will then be greeted with a confirmation page to initiate the Regeneration. On this screen, press enter to confirm.

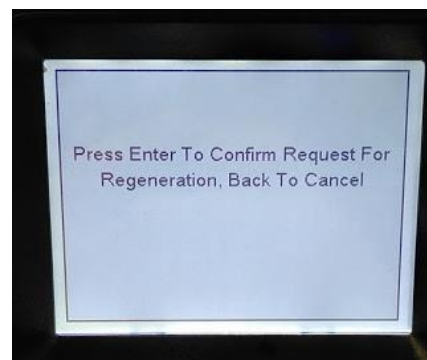
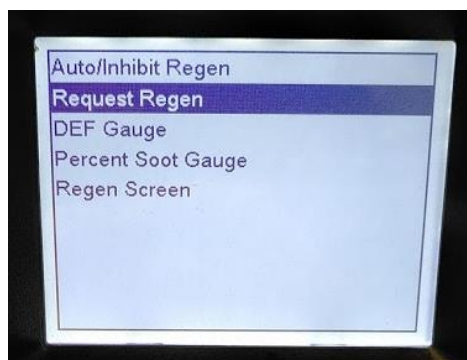

10) The Engine RPM will then increase automatically to conduct the full Regeneration. The symbol will now be solid.



11) The Engine will now run until completion of the Regeneration Cycle. This can take some time. Throughout the Cycle, the following symbols will appear simultaneously.

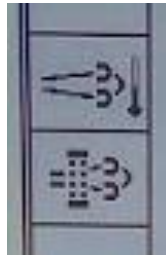

12) Once the Regeneration Cycle has finished, the Engine will return to idle. The following message will be displayed. This can be cleared by pressing enter.



13) Switch the Park and Neutral switches to the “off” position.

14) A Unit Power cycle (on then off) may be required to clear any remaining Regeneration symbols on the Control Panel screen.

15) To confirm that the Regeneration was successful. Cycle through to the information screen, and check to see that “DPF Level” is now at 0.

Actual RPM	Target RPM	Engine Battery	Run Hours
1000	1000	14.2 volts	13.50 Hrs
Engine Status	Status Time	Remote	Water
Running Loaded	00:00:00	REMOTE DISABLED	Off
Time	Unit pressure	Engine Temp	DPF Level
09:21:27 AM Date 27 Jul 20	0 bar	80.0 °C	0

**IMPORTANT NOTES:**

**Running unit on idle for prolonged periods will result in build-up of soot and require engine to complete a passive or forced regeneration.**

**Running the unit on prolonged periods at full load and full speed will clear the DPF and reduce the requirement for passive or forced regeneration.**





**Ignoring the requirement to complete a forced regen will result in the need for a service visit by a certified Kubota engineer.**

**Ignoring any warning codes on the engine may result in serious damage.**







**Incorrect oil will result in premature failure of the engine. Only oil recommended in the user manual must be used.**

## 4.5. Remote Operation

### 4.5.1. Starting the Engine

1. Switch on the Panel using the I/O Rocker switch.
2. Enter the PIN using the  &  Arrows and  buttons on the controller.
3. Press the remote function on the controller and press  to enable remote. Display will show "Remote enabled" the unit is now ready for remote control.

#### On the RCU:

4. Pull out red button on the base of the RCU to switch the handset on.
5. Follow the on screen instructions - Press and hold fully down both buttons 5 + 6 for 3 seconds, a beeping noise will emit from the RCU. RCU & receiver have now 'paired'. See fig 5.
6. Press button 2, the Start / Stop button on the RCU 
7. To increase engine speed, press the 'engine speed up' button, this is indicated by the symbol of a hare. See fig 5 
8. To decrease engine speed, press the red engine 'speed down' button, this is indicated by the symbol of a tortoise. See fig 5 
9. Press button 1, the water ON button, to divert the water to the nozzle or gun. See fig 5 
10. Press button 1 again, this will now divert the water back to tank See fig 5 
11. To stop the engine, reduce the Engine rpm press button 2 the start / stop button on the RCU. See fig 5 
12. \*\*The Remote-control unit will remain connected unless the user disables remote control function at the main controller or system is powered down.

When the engine has been stopped the RCU will turn itself off. To resume return to step 5

If the operator goes out of radio receiving range the system will automatically turn the water OFF (divert back to tank). When the operator steps back into radio receiving range, the status is healthy, and jetting can be resumed.





### Turning the unit ON

- Pull out the red button at the base of the RCU
- Press both buttons 5 & 6 together and hold for at least 3 seconds until a beep is heard. Once connected, the screen should display as per Fig. 5

### Turning the remote control OFF

- Turn the handset off by pressing the red STOP button

- |                 |   |                       |
|-----------------|---|-----------------------|
| <b>Button 1</b> |  | Water on / Water Off. |
| <b>Button 2</b> |  | Engine Start Stop     |
| <b>Button 3</b> | HI  | RPM up                |
| <b>Button 4</b> | LO  | RPM Down              |

No lights...RCU off.

Charging Details (See handbook for charging instructions).

#### **4.6. Rapid Shutdown**

**⚠** Should any unforeseen circumstances arise, including any signs of a leak, the jetting operation should be terminated immediately, the equipment shut down and the relevant managers informed.

#### **4.7. Automatic Shutdown**

The engine will shut down automatically if the monitoring and control system detects a malfunction. Possible reasons for an automatic shutdown are detailed in Section 6 - Fault Finding.

#### 4.8. Harben® Jump Jet

The Harben Jump Jet system is a unique and exceptionally effective addition to the Harben high pressure pump which increases the effective duct cleaning distance up to and often beyond 300m. When required the operator can switch on the Jump Jet to create a cyclic vibration in the jetting hose. The vibration travels along the entire length of the hose reducing friction between itself and the duct wall and allowing the de-silting nozzle to continue moving into the duct, cleaning as it goes.

Critically the Jump Jet allows ducts to be de-silted with pressures as low as 140 bar and only 40 l/min meaning that even with fibre optic cable in-situ there is negligible risk of causing any damage.

 To operate the jump jet, open the jump jet valve on the control panel of the unit.

#### 4.9. Hose reel winding and unwinding

The high-pressure hose is manually unwound and hydraulically wound by an OMR315 hydraulic motor, which is driven by a gear pump from the engine P.T.O.

The motor is fitted to the hub of the hose reel. The motor speed and direction is controlled via a manually actuated spool valve.

The hose reel motor speed can be adjusted up and down by a flow control knob.

Pushing the lever inwards towards the pump set will wind the hose reel in.

The normal practice is to unwind the hose by hand, only drawing off the required length of hose to reach the work site and then to wind the hose back in using the hydraulic motor.

It should be remembered that the hose cannot be wound using the hydraulic motor unless the engine is running.

Therefore, when a jetting operation is finished, wind in the hose before shutting down the engine. Wind in the hose before you intend to empty the tank.

 If the hose becomes stuck in the drain the hydraulic hose reel should NOT be used as a winch to try and free it and the towing vehicle should NEVER be driven away in an attempt to drag the hose clear. This will put severe strain on the reel framework which could lead to serious damage.

Hoses that have become stuck can sometimes be pulsed free using the Harben® Jump Jet™ kit or alternatively they should be pulled free by hand.

*NOTE: Do not exceed the maximum operating pressure by fitting a smaller nozzle than is recommended. This will cause the burst disc to open. The maximum engine speed is 2500 rpm*

*NOTE: The hose should NEVER be tightly wound onto the hose reel drum when the hose is not pressurised, as might occur when the hose has become trapped. A tightly wound hose can easily crush the hose reel when it is next pressurised. If you have reason to believe that the hose may have been tightly wound onto the reel when unpressurised it should be completely unwound and then rewound loosely before pressurising.*



## 4.10. Frost Precautions

During cold periods there is a risk of freezing overnight or when travelling on the road. Damage caused by freezing is expensive to repair and IS NOT COVERED UNDER WARRANTY. Take the following precautions to avoid frost damage:

### 4.10.1. To Anti-Freeze the machine with an antifreeze tank:

1. The valves to control the antifreeze procedure are located to the front of the unit. (See picture below).

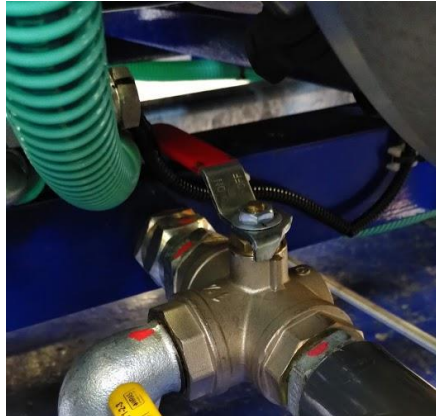

2. Put the Tank Drain valve (Red) into the DRAIN position and drain the water tanks. When the tanks have drained move the valve to the SHUT OFF position.



3. Put the jump jet valve into the "off" position, see below



4. Open the yellow valve from the tank marked ANTIFREEZE. This tank must be full of an antifreeze mixture with strength of no less than a 50/50 mix.



5. Remove the gun or any jetting nozzle from end of the hose and unreel 3m of hose.
6. Switch the selector from DUMP to HIGH PRESSURE
7. Hold the open-ended hose away from the body pointing it to the ground and away from any by-standers.
8. Start the engine and run at idle speed. Water will come from the end of the high-pressure hose. (It may be necessary to bleed the pump if water flow is very slow)
9. After a minute or two the blue antifreeze mixture will start to come out of the high-pressure hose. **IMMEDIATELY SWITCH OFF THE ENGINE.**
10. Place the end of the high-pressure hose into the antifreeze tank. If the hose is clean you may remove the strainer in the tank lid to make it easier.
11. Restart the engine and allow the antifreeze to circulate. Briefly (about 2 seconds) move the selector valve from HIGH PRESSURE to DUMP and back to HIGH PRESSURE. Briefly (about 4 seconds) put the 'jump jet' valve into the 'On' position and then return to the 'Off' position. See picture below.



12. Stop the engine by switching the ignition switch off. Leave the selector on HIGH PRESSURE.
13. Manually rewind the hose back on the reel and lock in position,

#### 4.10.2. To De-Antifreeze the machine:

1. Shut off the 2-way antifreeze valve.
2. Place the 3-way valve into the RUN Position. See picture below.



3. Re-fill the water storage tank.
4. Put jump jet valve into the 'off' position, see below.



5. Place the high-pressure hose (NO NOZZLE ATTACHED!) into the antifreeze tank.
6. Start the engine with the selector on 'HIGH PRESSURE'.
7. Pump out the antifreeze solution from the high-pressure hose back into the container.
8. As the antifreeze mix reaches the top of the tank turn engine off. (Regularly check the strength of the antifreeze mixture ensuring it is at least a 50/50 mix)
9. Place the jump jet valve in the on position.
10. The machine can now be used in the normal manner.

#### 4.10.3. To antifreeze without an antifreeze tank:

1. Prepare 50/50 antifreeze solution.
2. Remove nozzle or gun attachments from the delivery hose.
3. Lower the water level in the tanks using the drain valve immediately to right of the o/s wheel.
4. Pour antifreeze solution into the water tanks.
5. Restart the engine and run at idle, pump antifreeze solution through the high-pressure line and return line as required.

#### 4.10.4. To de-antifreeze:

**DO NOT ATTEMPT TO JET ANY REMAINING ANTIFREEZE SOLUTION INTO A CONTAINER**

**Rather.**

Consider the antifreeze solution as expendable and merely refill the tank for the next jetting operation. NEVER DISPOSE OF ANTIFREEZE INTO THE DRAINAGE NETWORK!

**Or**

With the engine switched off, drain the pump suction line into a container by unscrewing the inline strainer bowl to the bottom left side of the pump.

***NOTE: If the pump is frozen up, on no account should the unit be started until it has been thoroughly thawed.***

## 5. Routine Maintenance

Table 5.1 provides a basic guide to routine maintenance requirements for the various components of the trailer.

**Warning:** Maintenance should only be carried out with the engine turned off and when cold.

### 5.1. Maintenance Procedures

Table 1 indicates recommended routine maintenance tasks cross referenced to maintenance procedures.

Table 5.1 Recommended Routine Maintenance

	GENERAL
Prior to use / Daily / after 8 hours running	<ul style="list-style-type: none"> <li>• In cold weather check machine is not frozen before starting</li> <li>• Check inlet water filter element (Ref Para 6.2)</li> <li>• Check engine oil level on dip stick (Ref section 10)</li> <li>• Check radiator water level</li> <li>• Visual check for hose damage/water leaks</li> <li>• Check emergency stop button operation</li> <li>• Check high-pressure hose condition</li> <li>• Check for any loose nuts and bolts or damaged items</li> <li>• Check tyre pressure</li> </ul>
Weekly / 24 hours	<ul style="list-style-type: none"> <li>• Visually inspect the machine for safety, checking for any loose, damaged or missing parts.</li> <li>• Check air filter cleanliness (Ref section 10)</li> <li>• Check fuel filter for contamination (Ref section 10)</li> </ul>
Three monthly / 50 hours	<ul style="list-style-type: none"> <li>• First service contact Flowplant</li> <li>• Replace Pump Oil (only required for first service only)</li> </ul>
Six Monthly / 100 hours	<ul style="list-style-type: none"> <li>• Inspect tanks and fittings for leaks</li> <li>• Tighten any loose joints</li> <li>• Check condition of 12 volt start battery</li> <li>• Grease battery terminals for protection</li> <li>• Grease the hydraulic hose reel bearing blocks</li> </ul>
Yearly / 200 hours	<ul style="list-style-type: none"> <li>• Intermediate service of engine, gearbox and pump required (Contact Flowplant)</li> <li>• Closely inspect the structural integrity of the framework for signs of stress and cracking</li> <li>• Carry out detailed inspection of pipes, hoses and fittings.</li> <li>• Check unloader valve operation.</li> </ul>
Two Yearly / 400 hours	<ul style="list-style-type: none"> <li>• Major service of engine, gearbox and pump required (Contact Flowplant)</li> <li>• Check wiring terminals/connections and continuity of electrical earth.</li> </ul>

For a detailed guide to pump maintenance and overhaul procedures refer to [Section 7](#).

For routing engine maintenance please refer to the engine handbook supplied with the unit.

## 5.2. Daily Maintenance

The following must be completed daily with the trailer switched **OFF**.

1. Check condition of inlet water filter & element. Clean or replace. (Flowplant part no. N05105)

Unscrew the bowl to remove the mesh (Flowplant part no. N06021). Take precautions so as not to lose the sealing ring (Flowplant part no. N05108).



*Fig. 6.1 - Inlet Filter*

2.  Visually inspect all hoses for signs of chaffing or leaks. Report any damage immediately to supervisor or manager.

With the machine **running**:

3. Make further inspection for leaks. If a leak is observed, shut down immediately and report the leak to a supervisor or manager.

### 5.3. P-Pump Lubricating Oil

Manufacturer	Type
ESSO	Nuto H150
GULF	LP 150
MOBIL	DTE Extra Heavy
ROC	Kiron 150
TEXACO	Rando HD 150
BP	Energol HLP 150
AGIP	OSO 105
SHELL	Tellus/Morlina 150
CENTURY OIL	PWLM
PETROFINA	Hydran 51
CASTROL	Hyspin AWS 150

Oil Capacity (litres)			
Number of Cylinders			
3-cyl	4-cyl	6-cyl	8-cyl
6.5	6.0	5.75	5.0

## 5.4. P-Pump Burst Discs

Colour Code	Part Number	For Maximum Working Pressure
Yellow	011019	125 bar (1800 psi)
Blue	011020	140 bar (2000 psi)
Red	011021	175 bar (2500 psi)
Purple	011022	210 bar (3000 psi)
Green	011045	240 bar (3500 psi)
White	011046	275 bar (4000 psi)
Black	011047	345 bar (5000 psi)
Orange	011107	415 bar (6000 psi)



Fig. 6.2 Burst disc holder showing 'white' burst disc

Pressure discs should be replaced at least every 6 months to ensure continued safe operation and only manufacturer's original replacements should be used.

If Pressure relief valves are fitted these should be checked for functionality and certified by the manufacturer or their authorised representative at least every 6 months.



## 6. Fault Finding

Most of the problems experienced during jetting operations are likely to be caused by the pump or the associated hoses.

These types of problems are covered in the pump fault finding chart, which is repeated at 6.3 overleaf for convenience.

Also covered at 6.3 overleaf is a diagnosis of selector valve problems.

### 6.1. Shutdown Problems

Most problems which can cause the unit to shutdown will be indicated by one of the fault lamps on the engine controller See fig. 6.2 as follows:

## 6.2. Equipment Fault Finding

<b>Problem</b>	<b>Possible Cause</b>	<b>Recommended Action</b>
Low system pressure	1 Worn or incorrect size of cutting nozzle. 2 Engine speed slow. 3 Leaks from hose. Pipes and connections. 4 Blocked inlet filter. 5 Inlet hose too long. 6 Loss of water through dump line of selector valve or gun when high-pressure selected. 7 Loss of water through dump line of remote-control kit, if fitted.	Replace the old jetting Nozzle with a new one. Adjust to correct speed. Check the connections for tightness, replace if needed Clean or replace element. Shorten hose length. Check seats and seals.  Check seats and seals.
High System Pressure	1 Blocked nozzle, selector valve or gun. 2 Incorrect nozzle size. 3 Incorrect bore size. 4 Engine speed high. 5 Crushed delivery hose. 6 Two gun choke left in gun when operating as single gun unit.	Clean the items and flush out the delivery line. Replace the nozzle. Replace the hose. Adjust to correct speed. Replace if necessary. Replace with standard choke.
Low Water Level	1 Blocked or dirty pre-filters. 2 Faulty ball valve assembly. 3 Wrong seat in ball valve assembly. 4 Low inlet pressure.	Clean or replace elements. Replace if necessary. Replace the seat if necessary. Increase pressure.
Pump Not Running Evenly (also refer to pump faults).	1 Air in water. 2 Air in crankcase oil. 3 Worn drive coupling. 4 Faulty inlet or delivery valve. 5 Valve nut over tightened.	Water bleed pump. Oil bleed pump. Replace flexible elements and examine coupling. Check valve condition. Check tightness of inlet & delivery nut
Burst Disc failure or Safety Relief Valve Operating (also refer to high system pressure problem).	1 Incorrect burst disc. 2 Incorrect valve setting. 3 Faulty Valve. 4 Faulty or fatigued burst disc.	Replace with correct disc. Check certificate/setting. Repair or replace if required. Replace with new disc.

### 6.3. P-Pump Fault Finding

<b>Problem</b>	<b>Possible Cause</b>	<b>Recommended Action</b>
1 Mixing of Oil and Water in crankcase 2 Loss of pressure 3 Pump not running evenly	1 Worn or damaged delivery valves. 2 Damaged filter element allowing debris to jam delivery valve.	1 Check all delivery valves – replace as necessary. 2 Check all diaphragms – replace as necessary. 3 Replace oil. 4 Check filters – replace as necessary.
1 Loss of crankcase oil through high pressure hose  2 Loss of pump pressure 3 Pump not running evenly	1 Inlet restriction may have been caused through; <ul style="list-style-type: none"> <li>a. Blocked filters</li> <li>b. Kinked inlet hose</li> <li>c. Worn or damaged inlet valves</li> <li>d. Excessive inlet hose length</li> </ul> 2 Pump has been frozen	1 Clear restriction.  2 Check inlet valves – replace as necessary. 3 Check diaphragms – replace as necessary. 4 Replenish oil.
1 Mixing of Oil and Water in Crankcase	1 Diaphragm failure (may have been through fatigue from excessive running hours).	1 Check all diaphragms – replace as necessary.

DISTINGUISHING FEATURE OF FAILURE ON DIAPHRAGM

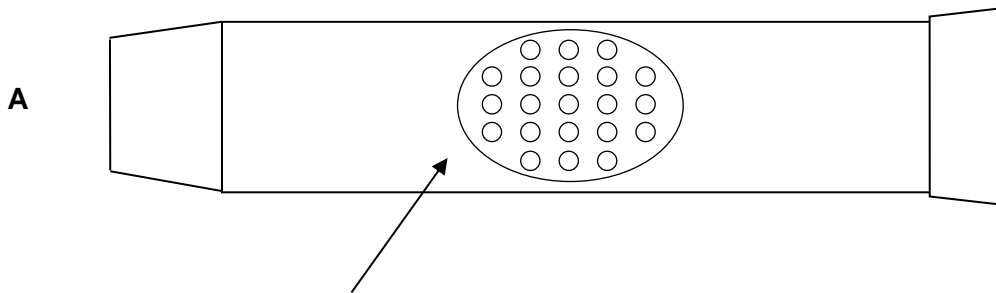

Impression of the baffle on diaphragm

Reason: Delivery valves worn or blocked

DISTINGUISHING FEATURE OF FAILURE ON DIAPHRAGM

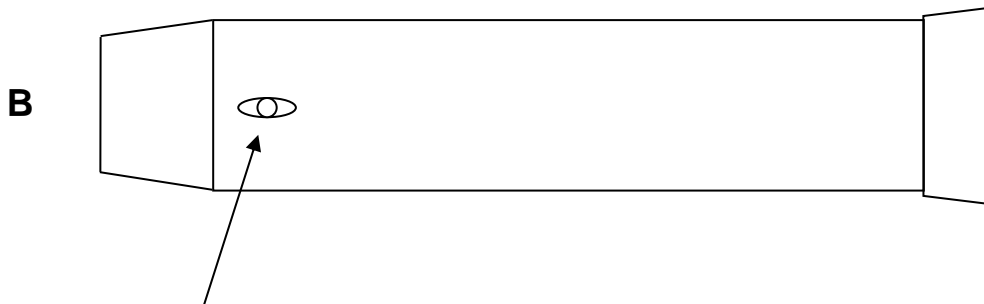

4 small impressions cause more damage on the inside, than on the outside.

Reason: Water filter blocked, or inlet valves blocked.

DISTINGUISHING FEATURE OF FAILURE ON DIAPHRAGM

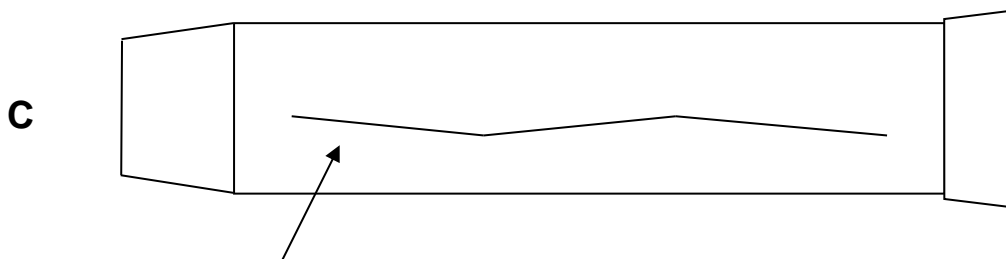

Shear through wall of diaphragm

Reason: Pump operated whilst frozen or wear and tear after several thousand hours

#### 6.4. Selector Fault Finding (see section 8)

Selector problem	Cause	Action
Loss of pressure and flow is down.	Water leaking through the worn seat back to tank.	Replace the seats and the plug if also damaged.
If water leaks along spindle and past lever.	O-ring and back up ring failure along shaft.	Replace O-ring and back up ring 013-021 & 023-001.
Water leaking along the gland nut thread.	Leaking selector seal.	Replace seal 012-095.

## 7. Pump

### P-Type

Refer to the P Type Pump Service Manual, part no. 061-352, included with the unit.

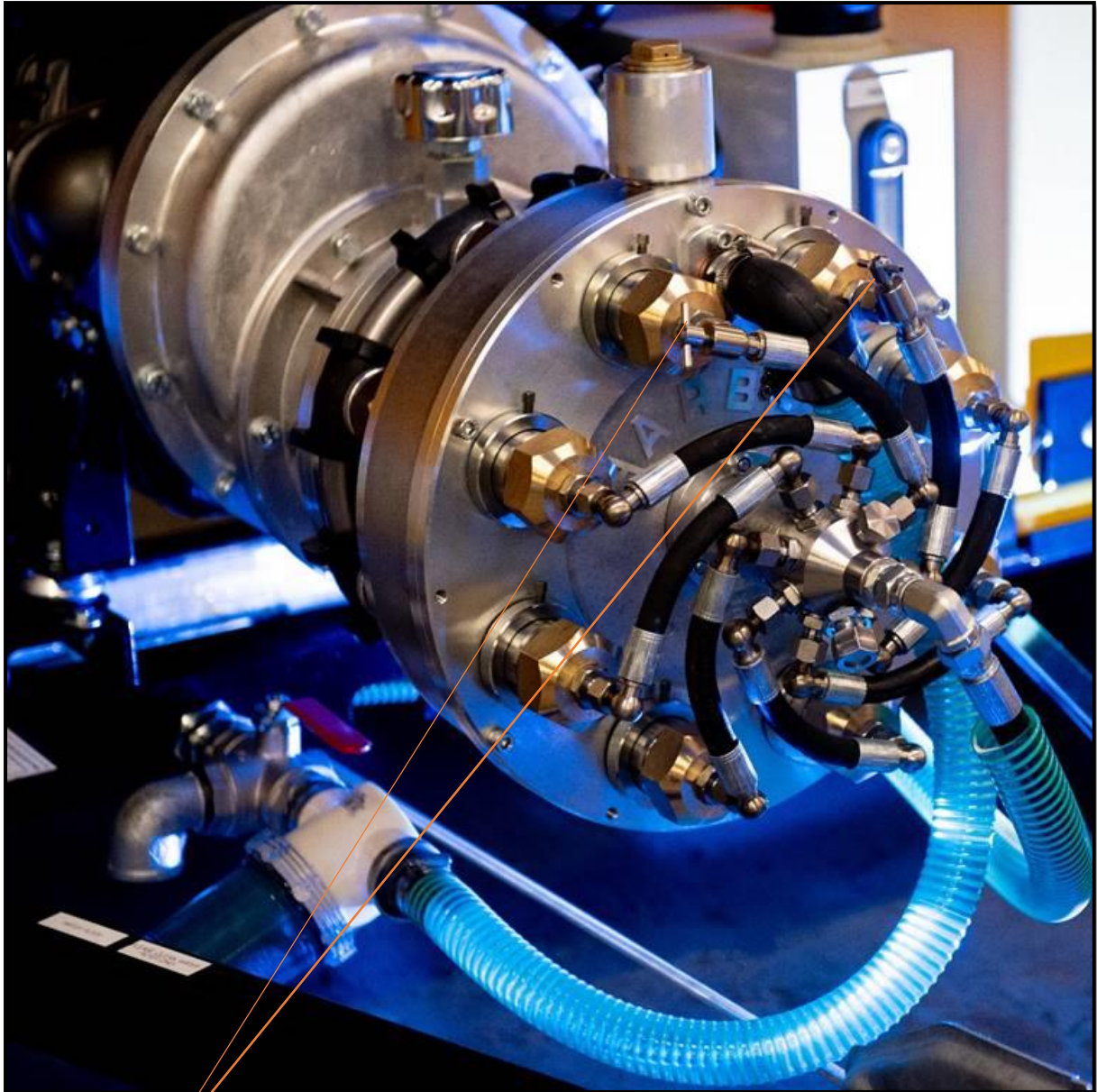

*Bleed Screws*

## 8. Circuit Diagrams

The following circuit diagrams are included in this section:

### Hydraulic circuit

This provides details of the unit's hydraulic circuit, the function of which is to power a hydraulic motor driven hose reel, winding high-pressure hose in or out whilst carrying out drain cleaning or other high-pressure water jetting applications.

### Water Circuit

This provides details of the water circuit, starting with the supply and ending with the delivery to the jetting application.

# 8.1. Hydraulic Circuit

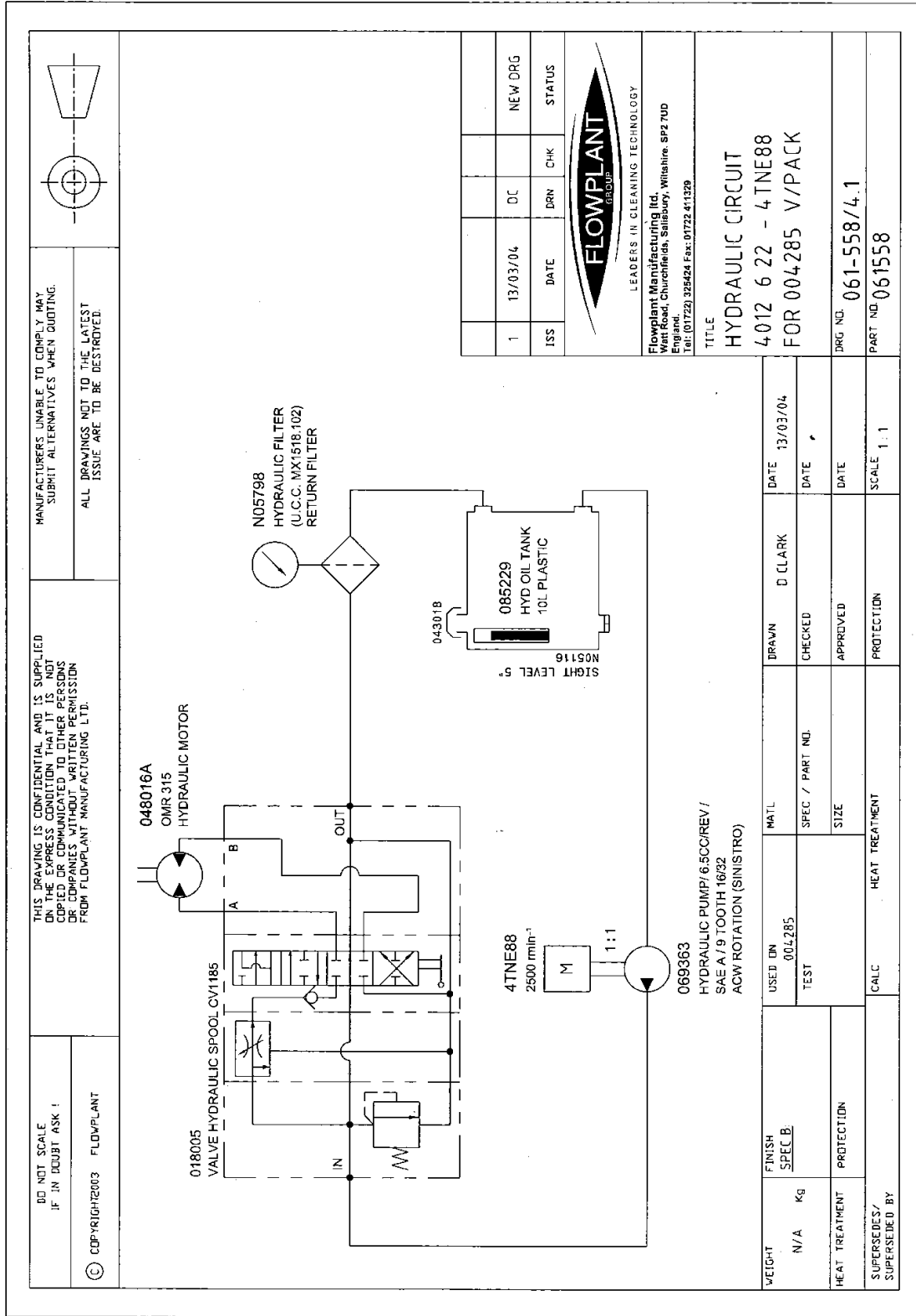



## 8.2. Water Circuit

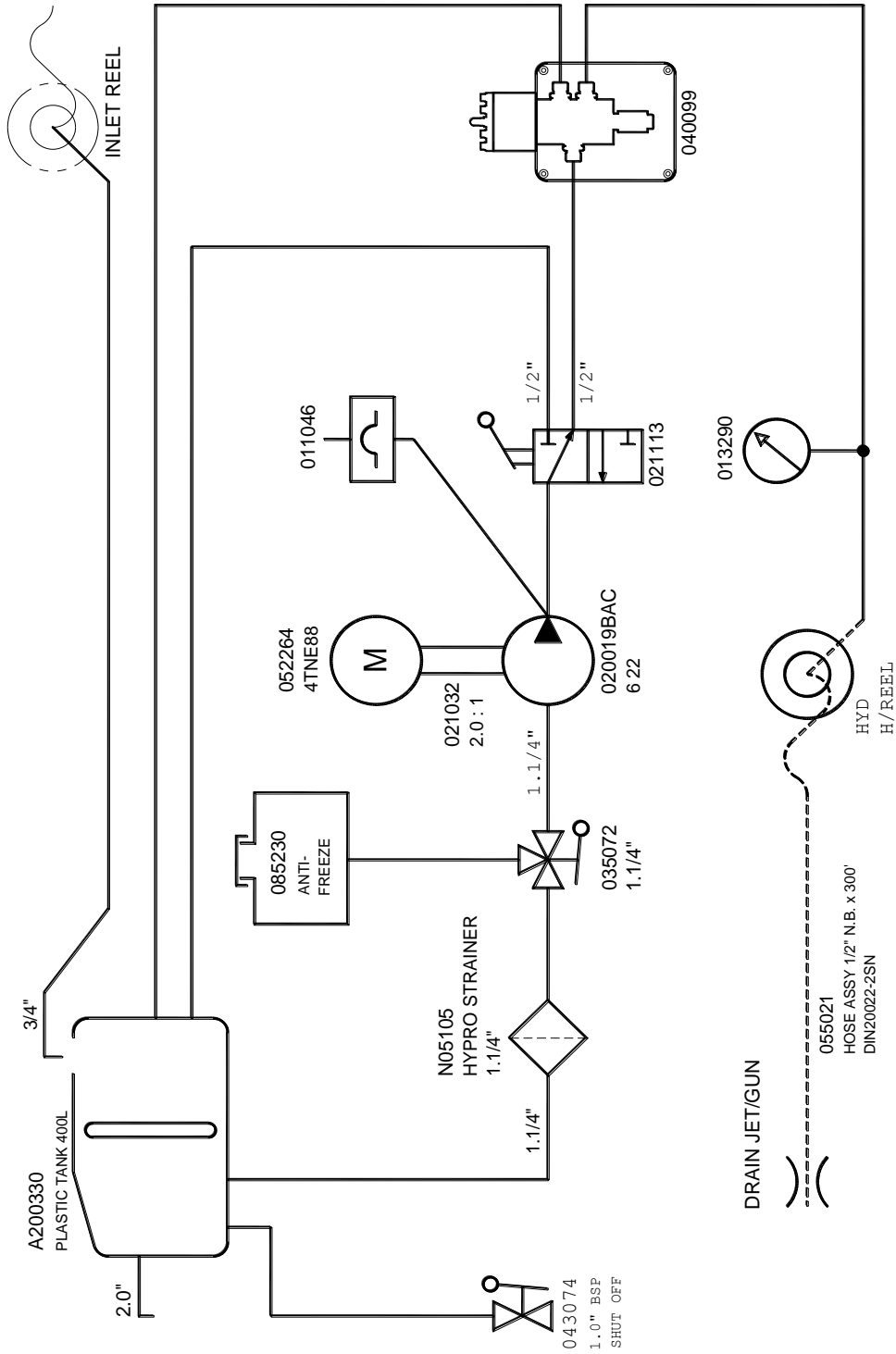

## 9. Diesel Engine

Copies of the Diesel Engine Manufacturer's Operators Handbook are supplied with this equipment.



## 10. Parts Lists / Spares

### 10.1. Introduction

This section includes advice on obtaining spare parts.

To identify consumable items and service kits you require you should use the information in this section. To identify components for the pump or engine etc, refer to the relevant parts in this manual.

### 10.2. Ordering Spare Parts

Order spare parts from:



#### **Flowplant Group Ltd**

Gemini House, Brunel Road, Churchfields Industrial Estate

Salisbury, Wiltshire, UK, SP2 7PU

Tel. +44 (0)1722 325424 – Fax. +44 (0)1722 411329

[sales@flowplant.com](mailto:sales@flowplant.com)

[www.flowplant.com](http://www.flowplant.com)

### 10.3. Parts List

004416 – Radio

Component	Description	Qty
011156	ELBOW INLET MANIFOLD (1 1/4" INLET)	1
011157	TUBE SUPPORT 1 1/4" INLET HOSE P PUMP	1
013039	ADAPTOR 1/2" BSP M x 1/2" BSP M 415 BAR C-TXT	3
013046	ADAPTOR 3/4" BSP M x 1/2" BSP M 345 BAR	1
013054	HOSE CLIP DIA 30-50 JCS HI-TORQUE S/S	1
013224	ADAPTOR BHEAD 1/2" BSPM x 1/2" BSPM 415BAR C/W LNUT	2
013266	SEAL DOWTY 1 1/4" BSP SELF CENTERING	18
013349	CLIP "R"	6
013375	LOCKNUT 1 1/4" BSP UPVC	4
013813	SCREW THREAD CUTTING PAN HEAD TORX DRIVE 6.0 mm x 16 mm ZINC PLATED	4
013853	SCREW SET HEX HD M12-1.75 100 LG ZINC PLATED	2
013946	M6 STUDDED AVM 18mm DIA M/M	4
014153	REFLECTOR SIDE MARKER (EEC APPROVED) SCREW ON TYPE	4
014288	HOSE CLIP DIA 8-10 JCS HI-TORQUE RS727-5914	2
014298	PANEL HOLE PLUG DIA. 50mm - DTB 500 ESSENTRA 466866	1
014304	316 STAINLESS STEEL CABLE TIE, 520MM x 4.6MM	10
015322	DTK500 1803 HYD PUMP O RING 82mm ID * 3/32	1
016398	COUPLING KUBOTA T4F D1803TI	1
016424	AV MOUNT HYDVC1400-40 (HYDROMOUNT M10)	2
016425	AV MOUNT HYDVC1400-70 (HYDROMOUNT M10)	2
018005	VALVE SPOOL HYD FLOW CONTROL	1
020041AAB	PUMP BARE SHAFT P 8 x 22 EN57 1000RPM 280 BAR	1
020143	GEARBOX HARBEN 2.0:1 SAE5 FLANGE	1
021020	BELL HOUSING PERKINS MACHINED	1
021059	SELECTOR ASSEMBLY INLINE 1/2" BSP	1
021090	ADAPTOR 3/4" BSPM x 3/8" BSPM 415 BAR	2
023011	ANGLE SWIVEL JOINT 90 DEG 1/2" BSP M/M 415BAR	1
023013	CAP BLANKING 1/2" BSP FEM SWIV MS ZN 415 BAR	1
023030	INSERT FOR HOSE SWAGED 3/4" BSP FEM	1
023041	O CLIP 3/4"	4
023047	HOSE CLIP DIA 30-40 JCS HI-GRIP S/S	12
023082	INSERT HOSE 3/8" BSP 90 DEG FEMALE	2
023088	COUPLING Pt1 B140 O'SIZE FLEX BORE 30 KEY 8	1
023093	COUPLING PART 4 B140 BORE 30MM KEY 8MM MACHINED	2
0231046	CROSS 1 1/4" BSP F/F/F/F LOW PRESSURE GALVANISED	1
0231414	INSERT HOSE 1/8" BSP 90 DEG FEMALE	1
023148	INSERT FOR HOSE SWAGED 1/2" BSP 90 DEG FEM	2
023261	ADAPTOR 1/2" BSPM x 1/2" BSPF SWIVEL 415 BAR ZINC	2
023262	ADAPTOR 1/2" BSP FEMALE FIXED TEE 415 BAR	2
023362	ADAPTOR 1/2" BSP M x 7/8"-14 JIC M 415BAR	1

023363	ADAPTOR 3/4"BSP M x 7/8"-14JIC M 345 BAR	1
023379	ADAPTOR BHEAD 1 1/4" BSPM x 1 1/4" BSPM 210 BAR C/W NUT	1
023406	TEE 1/2"Mx1/2"Mx1/2"F SWIVEL ALL BSP 415BAR ZN MUST HAVE HEX BODY AND NOT ROUND FORGED	1
023569	PIN CANOPY RETAINER	6
023847	ADAPTOR 1.1/4" BSP M/F SWIV 2B/20 210 BAR	2
028004	FRAME HYD HOSE REEL DTW (POWDER COAT)	1
028032	CLAMP BATTERY DTW (POWDER COAT)	1
031330	HANDWHEEL PLASTIC TAPPED M12 (GUN HOLDER, HOVERVAC)	2
031431	ROTARY JOINT GUARD (POWDER COAT)	1
032088	CLAMP FORWARD HANDLE MARK 2 GUN MACHINED	4
032194	ADAPTOR 3/4"BSP M x 1/2"BSP F FIXED 900BAR S/S	1
033005	ADAPTOR 3/8" BSP M x 3/8" BSP M 415 BAR	4
033006	ADAPTOR 1/2" BSP M x 3/8" BSP M 415 BAR ZN	5
033010	SEAL BONDED 1/2" BSP 400-825-4490-41 448 BAR SELF CENTRALISING	17
033013	SEAL BONDED 3/8" BSP 400-823-4490-41 492 BAR SELF CENTRALISING	4
033014	SEAL BONDED 3/4" BSP 400-827-4490-41 420 BAR SELF CENTRALISING REPLACES A041271	5
033058	HOSE ASSY 1/2" 00.81m STR/ELB 1/2"BSPF EN 853 2SN	2
033069	HOSE ASSY 1/2" 00.64M STR/ELB 1/2"BSPF SAE100R2AT	1
035072	VALVE 1 1/4"BSP T PORT 375 PSI FIG 2000 S/R TYPE 98 ALBION	1
035077A	POLY FLOAT 6" X 5/16"	1
035210	VALVE BALL FLOAT VALVE 3/4" HP 300 PSI (WITH BRASS LOCK NUTS)	1
041029	GROMMET 25.4M/M BLACK PVC BLANK	4
041031	GROMMET CABLE RB3466TPR CTEXT	4
041034	STUDDING M10 ZINC PLATED [PER 1.5 METRE] c-txt	1
0421805	SUPPORT HOSEREEL O/S DTB II (POWDER COAT)	1
0421806	SUPPORT HOSEREEL N/S DTB II (POWDER COAT)	1
0421807	PANEL INNER WING DTB II (POWDER COAT)	2
0421812	FRONT SUPPORT ARM (O/S) TANK DTB 500 (POWDER COAT)	1
0421813	FRONT SUPPORT ARM (N/S) TANK DTB 500 (POWDER COAT)	1
0421823	MOUNT BALLCOCK DTB 500 (POWDER COAT)	1
0421892	LABEL BRACKET DTB500 (POWDER COAT)	1
0422487	BRACKET DTB500 NUMBER PLATE (POWDER COAT)	1
0422547	BRACKET FRONT LIGHT DTB500 (POWDER COAT)	2
0422633	LIGHT MOUNTING BRACKET - OFFSIDE - DTB500 (POWDER COAT)	1
0422634	LIGHT MOUNTING BRACKET - NEARSIDE - DTB500 (POWDER COAT)	1
0422875	VALANCE DTB500 MK2 PLATE TYPE	2
0423184	BRACKET RAIN FLAP DTB500 2018	2
0423362	INSTRUMENT SUPPORT PANEL DTK500 KUBOTA 1803	1
0423363	FRONT SUPPORT WATER TANKS DTK KUBOTA 1803	1
0423369	ECU SUPPORT PLATE DTB500 KUBOTA D1803	1
0423373	DTK500 DIVERTOR VALVE BRACKET	1
0423448	DTK500 FUEL PUMP AND FILTER BRACKET	1
0423452	DTK500 EXHAUST SUPPORT BRACKET	1
0423471	DTK SELECTOR BLANKING PLATE	1

0423495	DTK500 CONTROL BOX REAR COVER PLATE	1
0423501	DTB500 REAR TRIANGLE ASSEMBLY	2
0423528	DTK500 RELAY BRACKET MK2	1
0423529	DTK500 CONTROL BOX COVER MK2	1
043018	CAP HYD/FUEL TANK	2
043061	HOSE CLIP DIA 9.5-12 JCS HI-GRIP S/S	8
043139	GROMMET BLACK RIBBED 80 x 40	2
043196	ELBOW 90 DEG. THREADED 1 1/4" BSPF UPVC	4
043222	INSERT HOSE 1 1/4"BSPM X 32 MM DIA HOSETAIL UPVC	12
043235	ADAPTOR FLANGED 1 1/4"BSPM X 1 1/4" BSPM UPVC	4
044548	DTK 500 2019 FRAME	1
048005	BEARING HOSE REEL HYD P TYPE (POWDER COAT)	1
048016A	MOTOR HYDRAULIC DANFOSS OMR 315 (POWDER CAT)	1
048103	TUBE WATER OUTLET FOR HYDRAULIC HOSE REEL N15-142 AND 048-110	1
048110	HOSEREEL DRUM P TYPE BOLTED FLANGE (POWDER COAT)	1
052377	ENGINE 1803 KUBOTA STAGE 5 COMPLETE ASSEMBLY	1
053002	EXHAUST CLAMP 1 7/8"	2
053155	EXHAUST TAILPIPE (POWDER COAT)	1
054125	ENGINE OIL 15W40 CJ4 Q8 FORMULA TRUCK 7000	6
055024	HOSE 1/2" P.V.C. CLEAR BRAIDED [PER METRE] HDPVC12	2
055058	HOSE ASSY 3/8" 02.46M STR/ELB 3/8"BSPF EN 853 2SN	1
055063	HOSE 1 1/4" HELIFLEX [PER METRE]	8
0551093	HOSE ASSY 1/4" BSP COMP ELB/COMP ELB DIN 20022 2SN 0.700m LG	2
055149	HOSE ASSY 3/8" 00.57M ELB/ELB 3/8"BSPF EN 853 2SN 270 DEGREES (ON DTB THIS IS THE TOP HOSE)	1
055150	HOSE ASSY 3/8" 00.54M ELB/ELB 90 DEG 3/8"BSPF EN 853 2SN (ON DTB THIS IS THE BOTTOM HOSE)	1
055175	HOSE ASSY 3/8" 00.38M STR/ELB 3/8"BSPF EN 853 2SN	2
055182	HOSE ASSY 3/8" 02.07M STR/ELB 3/8"BSPF EN 853 2SN	2
055207	HOSE ASSY 1/2" 2.6M STR/ELB 1/2" BSPF EN 853 2SN	1
055450	HOSE SAFETY LEADER 3/4" X 3/4"BSP FEMALE/MALE ENDS 4000PSI WP	1
055994	HOSE ASSY DN10 3/8" PW2-06 0.655M CUT LGTH ELB/ELB 270 DEG	1
059116	WATER TANK 250LTR DTB 2019 BLUE RAL 5002	2
061033	SPACER PACKING D.T.T.	6
061067	WASHER SEATING FOR 1/4"BSP GAUGE	1
061088	SCREW SELF TAPPING 1/2" x 8 STEEL PAN HEAD	8
061352	MANUAL P-PUMP/ HI LIFT	1
061577	SAFETY AWARENESS SHEET FOR GENERAL H/P JETTING EQUIPMENT	1
061663	LABEL OPERATING PROCEDURE DRAIN ASSY DTB500	1
061829	STATUTORY LABEL PLATE TRAILER	1
061880	PEEL AWAY SAFETY STICKER	1
061886	USB MANUALS	1
061899	DTB DESILTER SERVICE INTERVALS/FROST WARNING	1
061970	LABEL - READ MANUAL AND HEALTH AND SAFETY MANUAL	1
061971	UNIT AND HEALTH AND SAFETY MANUAL - DTK500	1
061988	LABEL RELAY BOX DTK500	1

067779	SAFETY VALVE VS500 C-TXT	1
069581	KIT HYDRAULIC DIVERT VALVE INSTALLATION - Mk2	1
069589	HYDRAULIC PUMP/ 6.5CC/REV /SAE A/ 9 TOOTH 16/32 RHD	1
071001	BATTERY 12V HEAVY DUTY TYPE 644	1
071008	REFLECTOR TRIANGLE	2
0711021	13 PIN PLUG ADAPTOR, 13 PIN TRAILER 7 PIN CAR 0-695-69	1
0711024	8MM SADDLE TYPE CABLE TIE MOUNT RS PT NO. 666-739	8
0711029	LIGHT REAR COMBINATION INDICATOR/TAIL/STOP 151BAR	2
0711031	LIGHT REGISTRATION LED 12V BRITAX L868.00LDV	2
0711032	LIGHT FOG LED 12/24VDC 81FM	1
0711033	LIGHT REVERSE LED 12/24VDC 81WM	1
0711036	LIGHT/REFLECTOR FRONT LED 12/24VDC 44WME	2
0711040	PVC CABLE GROMMET 9MM MAX. CABLE, 15MM HOLE DIAM.	4
0711240	TELERADIO RADIO CONTROL SYSTEM CANOPEN - TRANSMITTER AND RECIEVER	1
0711242	PRESSURE TRANSMITTER 0-300 BAR 4-20mA	1
0711340	12V CIGARETTE LIGHTER OUTLET PIXNOR UNIVERSAL WATERPROOF WITH CAP PANEL MOUNT	1
0711345	HEAT SHRINK 1.5M LONG 32MM/8MM SHRUNK	1
0711382	CONTROL PANEL MURPHY MPC-20 CUSTOM FRONT	1
0711383	WIRING LOOM CONTROL PANEL MPC-20 SINGLE 21 PIN CONNECTOR	1
0711390	GASKET FOR MPC-20 CONTROLLER	1
0711408	ROCKER SWITCH ON/OFF BLACK 21A @ 14V SPST IP56 LATCHING	3
071141	LEAD BATTERY 610mm NEGATIVE 12v	1
0711460	DTK 500 KLAXON / SIREN	1
0711462	HARNESS DTK500 D1803 RADIO	1
0711472	RELAY AUTOMOTIVE 40A WITH DIODE 12V	1
0711492	LEAD BATTERY 1300mm POSITIVE 12V	1
071367	E STOP TWIST TO RELEASE including NC ACTUATOR 78-3724 78-3732	1
071412	FLOAT SWITCH R HORIZONTAL NYLON NO/NC 338-9722 Nitrile gasket	1
071665	RELAY 12VDC 40A IMO SRJH-1A-C1S FOR WKS96	3
071988	PLUG 13 PIN TRAILER P13PN	1
071989	CABLE TRAILER 13 CORE GTW131 (50m ROLL MINIMUM ORDER)	6
071992	CABLE TRAILER 2 CORE BROWN AND WHITE TTW1.0BRW 2 X 1MM SQ	8
073069	HEAT SHRINKABLE SLEEVING 9.5MM BORE (RS398-177)	1
078417	EXTENDED HEX NUT M8	1
078773	OUTER FLANGE HOSE REEL (POWDER COAT)	1
079245	FLANGE ADAPTOR EXHAUST DTB500	1
079275	EXHAUST STUB KUBOTA 1803	1
081159	COUPLING KFG20 KNOTT 2000KG	1
081217	BRAKE CABLE 830/1040MM	2
081218	COMPENSATOR KIT (EQUALISER) - DTB500 SINGLE AXLE	1
081221	WHEEL AND TYRE 18570R13 TO SUIT DTB500/DTK500	2
081222	AXLE DTB500 1800KG BRAKE 250/40	1
082133	RAINFLAP DTB500	2
082137	JOCKEY WHEEL TO SUIT KFG20 DTB 500	1

082143	NUMBER PLATE MOUNTING BRACKET	1
082160	CANOPY PLASTIC DTK TRAILER 500 2019	1
082161	LOOSE WHEEL NUT INDICATORS 27MM (PACK 100)	10
085263	HYDRAULIC TANK DTB500	1
085341	TANK FUEL PLASTIC DTB500 MK2 40L	1
088042	EXHAUST LAGGING GW304 FORTAGLAS WEBBING 76 X 3MM 35050.76 ARCO REF	5
105204	BRACKET FOR HYD SELECTOR HV39 (POWDER COAT)	1
7002259	GUIDE HOSE FEED ASSY DTK	1
A030376	LID, SCREW INSPECTION COVER(6)BLACK.	1
A041024	SCREW CAPSCREW M10 X 50MM LONG SOCKET HD	2
A060574	FITTING TEE 1 1/4" BSP FEMALE UPVC	1
N01241	BARREL NIPPLE 1 1/4 BSP GALV	1
N01282	ELBOW 1 1/4 BSP MXF MALLEABLE GALV	1
N01496	ELBOW 1/2-1/2 BSP Mx F 90 COMPACT FORGED 415BAR	2
N02230	ADAPTOR 1/2" BSPM X 1/8" BSPM ZN	1
N05105	LINE STRAINER 1 1/4" (HYPRO)	1
N05114	SIGHT GLASS 10"	2
N05116	SIGHT LEVEL GAUGE 5116/7	1
N05386	LINK HOSE E 1/4" R2AT X 8 1/2" COMPACT ELB/ELB	1
N05798	HYDRAULIC FILTER (U.C.C. MX1518.102) RETURN FILTER	1
N10001	BATTERY RETAINING BRACKET	1



## 004424 – Manual

<b>Component</b>	<b>Description</b>	<b>Qty</b>
011156	ELBOW INLET MANIFOLD (1 1/4" INLET)	1
011157	TUBE SUPPORT 1 1/4" INLET HOSE P PUMP	1
013039	ADAPTOR 1/2" BSP M x 1/2" BSP M 415 BAR C-TXT	3
013046	ADAPTOR 3/4" BSP M x 1/2" BSP M 345 BAR	1
013054	HOSE CLIP DIA 30-50 JCS HI-TORQUE S/S	1
013224	ADAPTOR BHEAD 1/2" BSPM x 1/2" BSPM 415BAR C/W LNUT	2
013266	SEAL DOWTY 1 1/4" BSP SELF CENTERING	18
013349	CLIP "R"	6
013375	LOCKNUT 1 1/4" BSP UPVC	4
013813	SCREW THREAD CUTTING PAN HEAD TORX DRIVE 6.0 mm x 16 mm ZINC PLATED	4
013853	SCREW SET HEX HD M12-1.75 100 LG ZINC PLATED	2
013946	M6 STUDDERED AVM 18mm DIA M/M	4
014153	REFLECTOR SIDE MARKER (EEC APPROVED) SCREW ON TYPE	4
014288	HOSE CLIP DIA 8-10 JCS HI-TORQUE RS727-5914	2
014298	PANEL HOLE PLUG DIA. 50mm - DTB 500 ESSENTRA 466866	1
015322	DTK500 1803 HYD PUMP O RING 82mm ID * 3/32	1
016398	COUPLING KUBOTA T4F D1803TI	1
016424	AV MOUNT HYDVC1400-40 (HYDROMOUNT M10)	2
016425	AV MOUNT HYDVC1400-70 (HYDROMOUNT M10)	2
018005	VALVE SPOOL HYD FLOW CONTROL	1
020041AAB	PUMP BARE SHAFT P 8 x 22 EN57 1000RPM 280 BAR	1
020143	GEARBOX HARBEN 2.0:1 SAE5 FLANGE	1
021020	BELL HOUSING PERKINS MACHINED	1
021059	SELECTOR ASSEMBLY INLINE 1/2" BSP	1
021090	ADAPTOR 3/4" BSPM x 3/8" BSPM 415 BAR	2
023011	ANGLE SWIVEL JOINT 90 DEG 1/2" BSP M/M 415BAR	1
023013	CAP BLANKING 1/2" BSP FEM SWIV MS ZN 415 BAR	1
023030	INSERT FOR HOSE SWAGED 3/4" BSP FEM	1
023041	O CLIP 3/4"	4
023047	HOSE CLIP DIA 30-40 JCS HI-GRIP S/S	12
023082	INSERT HOSE 3/8" BSP 90 DEG FEMALE	2
023088	COUPLING Pt1 B140 O'SIZE FLEX BORE 30 KEY 8	1
023093	COUPLING PART 4 B140 BORE 30MM KEY 8MM MACHINED	2
0231046	CROSS 1 1/4" BSP F/F/F/F LOW PRESSURE GALVANISED	1
0231414	INSERT HOSE 1/8" BSP 90 DEG FEMALE	1
023148	INSERT FOR HOSE SWAGED 1/2" BSP 90 DEG FEM	2
023261	ADAPTOR 1/2" BSPM x 1/2" BSPF SWIVEL 415 BAR ZINC	2
023262	ADAPTOR 1/2" BSP FEMALE FIXED TEE 415 BAR	1
023362	ADAPTOR 1/2" BSP M x 7/8"-14 JIC M 415BAR	1
023363	ADAPTOR 3/4" BSP M x 7/8"-14 JIC M 345 BAR	1
023379	ADAPTOR BHEAD 1 1/4" BSPM x 1 1/4" BSPM 210 BAR C/W NUT	1

023406	TEE 1/2"Mx1/2"Mx1/2"F SWIVEL ALL BSP 415BAR ZN MUST HAVE HEX BODY AND NOT ROUND FORGED	1
023569	PIN CANOPY RETAINER	6
023847	ADAPTOR 1.1/4" BSP M/F SWIV 2B/20 210 BAR	1
028004	FRAME HYD HOSE REEL DTW (POWDER COAT)	1
028032	CLAMP BATTERY DTW (POWDER COAT)	1
031330	HANDWHEEL PLASTIC TAPPED M12 (GUN HOLDER, HOVERVAC)	2
031431	ROTARY JOINT GUARD (POWDER COAT)	1
032088	CLAMP FORWARD HANDLE MARK 2 GUN MACHINED	4
032194	ADAPTOR 3/4"BSP M x 1/2"BSP F FIXED 900BAR S/S	1
033005	ADAPTOR 3/8" BSP M x 3/8" BSP M 415 BAR	4
033006	ADAPTOR 1/2" BSP M x 3/8" BSP M 415 BAR ZN	5
033010	SEAL BONDED 1/2" BSP 400-825-4490-41 448 BAR SELF CENTRALISING	17
033013	SEAL BONDED 3/8" BSP 400-823-4490-41 492 BAR SELF CENTRALISING	4
033014	SEAL BONDED 3/4" BSP 400-827-4490-41 420 BAR SELF CENTRALISING REPLACES A041271	5
033069	HOSE ASSY 1/2" 00.64M STR/ELB 1/2"BSPF SAE100R2AT	1
035072	VALVE 1 1/4"BSP T PORT 375 PSI FIG 2000 S/R TYPE 98 ALBION	1
035077A	POLY FLOAT 6" X 5/16"	1
035210	VALVE BALL FLOAT VALVE 3/4" HP 300 PSI (WITH BRASS LOCK NUTS)	1
041029	GROMMET 25.4M/M BLACK PVC BLANK	4
041031	GROMMET CABLE RB3466TPR CTEXT	4
041034	STUDDING M10 ZINC PLATED [PER 1.5 METRE] c-txt	1
0421805	SUPPORT HOSEREEL O/S DTB II (POWDER COAT)	1
0421806	SUPPORT HOSEREEL N/S DTB II (POWDER COAT)	1
0421807	PANEL INNER WING DTB II (POWDER COAT)	2
0421812	FRONT SUPPORT ARM (O/S) TANK DTB 500 (POWDER COAT)	1
0421813	FRONT SUPPORT ARM (N/S) TANK DTB 500 (POWDER COAT)	1
0421823	MOUNT BALLCOCK DTB 500 (POWDER COAT)	1
0421892	LABEL BRACKET DTB500 (POWDER COAT)	1
0422487	BRACKET DTB500 NUMBER PLATE (POWDER COAT)	1
0422547	BRACKET FRONT LIGHT DTB500 (POWDER COAT)	2
0422633	LIGHT MOUNTING BRACKET - OFFSIDE - DTB500 (POWDER COAT)	1
0422634	LIGHT MOUNTING BRACKET - NEARSIDE - DTB500 (POWDER COAT)	1
0422875	VALANCE DTB500 MK2 PLATE TYPE	2
0423184	BRACKET RAIN FLAP DTB500 2018	2
0423362	INSTRUMENT SUPPORT PANEL DTK500 KUBOTA 1803	1
0423363	FRONT SUPPORT WATER TANKS DTK KUBOTA 1803	1
0423369	ECU SUPPORT PLATE DTB500 KUBOTA D1803	1
0423448	DTK500 FUEL PUMP AND FILTER BRACKET	1
0423452	DTK500 EXHAUST SUPPORT BRACKET	1
0423495	DTK500 CONTROL BOX REAR COVER PLATE	1
0423501	DTB500 REAR TRIANGLE ASSEMBLY	2
0423528	DTK500 RELAY BRACKET MK2	1

0423529	DTK500 CONTROL BOX COVER MK2	1
043018	CAP HYD/FUEL TANK	2
043061	HOSE CLIP DIA 9.5-12 JCS HI-GRIP S/S	8
043139	GROMMET BLACK RIBBED 80 x 40	2
043196	ELBOW 90 DEG. THREADED 1 1/4" BSPF UPVC	4
043222	INSERT HOSE 1 1/4"BSPM X 32 MM DIA HOSETAIL UPVC	12
043235	ADAPTOR FLANGED 1 1/4"BSPM X 1 1/4" BSPM UPVC	4
044548	DTK 500 2019 FRAME	1
048005	BEARING HOSE REEL HYD P TYPE (POWDER COAT)	1
048016A	MOTOR HYDRAULIC DANFOSS OMR 315 (POWDER CAT)	1
048103	TUBE WATER OUTLET FOR HYDRAULIC HOSE REEL N15-142 AND 048-110	1
048110	HOSEREEL DRUM P TYPE BOLTED FLANGE (POWDER COAT)	1
052377	ENGINE 1803 KUBOTA STAGE 5 COMPLETE ASSEMBLY	1
053002	EXHAUST CLAMP 1 7/8"	2
053155	EXHAUST TAILPIPE (POWDER COAT)	1
054125	ENGINE OIL 15W40 CJ4 Q8 FORMULA TRUCK 7000	6
055024	HOSE 1/2" P.V.C. CLEAR BRAIDED [PER METRE] HDPVC12	2
055063	HOSE 1 1/4" HELIFLEX [PER METRE]	8
055175	HOSE ASSY 3/8" 00.38M STR/ELB 3/8"BSPF EN 853 2SN	2
055182	HOSE ASSY 3/8" 02.07M STR/ELB 3/8"BSPF EN 853 2SN	2
055207	HOSE ASSY 1/2" 2.6M STR/ELB 1/2" BSPF EN 853 2SN	1
059116	WATER TANK 250LTR DTB 2019 BLUE RAL 5002	2
061033	SPACER PACKING D.T.T.	6
061067	WASHER SEATING FOR 1/4"BSP GAUGE	1
061088	SCREW SELF TAPPING 1/2" x 8 STEEL PAN HEAD	8
061352	MANUAL P-PUMP/ HI LIFT	1
061577	SAFETY AWARENESS SHEET FOR GENERAL H/P JETTING EQUIPMENT	1
061663	LABEL OPERATING PROCEDURE DRAIN ASSY DTB500	1
061829	STATUTORY LABEL PLATE TRAILER	1
061880	PEEL AWAY SAFETY STICKER	1
061886	USB MANUALS	1
061899	DTB DESILTER SERVICE INTERVALS/FROST WARNING	1
061970	LABEL - READ MANUAL AND HEALTH AND SAFETY MANUAL	1
061971	UNIT AND HEALTH AND SAFETY MANUAL - DTK500	1
061988	LABEL RELAY BOX DTK500	1
067779	SAFETY VALVE VS500 C-TXT	1
069589	HYDRAULIC PUMP/ 6.5CC/REV /SAE A/ 9 TOOTH 16/32 RHD	1
071001	BATTERY 12V HEAVY DUTY TYPE 644	1
071008	REFLECTOR TRIANGLE	2
0711021	13 PIN PLUG ADAPTOR, 13 PIN TRAILER 7 PIN CAR 0-695-69	1
0711024	8MM SADDLE TYPE CABLE TIE MOUNT RS PT NO. 666-739	8
0711029	LIGHT REAR COMBINATION INDICATOR/TAIL/STOP 151BAR	2
0711031	LIGHT REGISTRATION LED 12V BRITAX L868.00LDV	2
0711032	LIGHT FOG LED 12/24VDC 81FM	1

0711033	LIGHT REVERSE LED 12/24VDC 81WM	1
0711036	LIGHT/REFLECTOR FRONT LED 12/24VDC 44WME	2
0711040	PVC CABLE GROMMET 9MM MAX. CABLE, 15MM HOLE DIAM.	4
0711242	PRESSURE TRANSMITTER 0-300 BAR 4-20mA	1
0711340	12V CIGARETTE LIGHTER OUTLET PIXNOR UNIVERSAL WATERPROOF WITH CAP PANEL MOUNT	1
0711345	HEAT SHRINK 1.5M LONG 32MM/8MM SHRUNK	1
0711382	CONTROL PANEL MURPHY MPC-20 CUSTOM FRONT	1
0711383	WIRING LOOM CONTROL PANEL MPC-20 SINGLE 21 PIN CONNECTOR	1
0711390	GASKET FOR MPC-20 CONTROLLER	1
0711408	ROCKER SWITCH ON/OFF BLACK 21A @ 14V SPST IP56 LATCHING	3
071141	LEAD BATTERY 610mm NEGATIVE 12v	1
0711460	DTK 500 KLAXON / SIREN	1
0711472	RELAY AUTOMOTIVE 40A WITH DIODE 12V	1
0711482	HARNESS DTK500 D1803 MANUAL	1
0711492	LEAD BATTERY 1300mm POSITIVE 12V	1
071367	E STOP TWIST TO RELEASE including NC ACTUATOR 78-3724 78-3732	1
071412	FLOAT SWITCH R HORIZONTAL NYLON NO/NC 338-9722 Nitrile gasket	1
071665	RELAY 12VDC 40A IMO SRJH-1A-C1S FOR WKS96	3
071988	PLUG 13 PIN TRAILER P13PN	1
071989	CABLE TRAILER 13 CORE GTW131 (50m ROLL MINIMUM ORDER)	6
071992	CABLE TRAILER 2 CORE BROWN AND WHITE TTW1.0BRW 2 X 1MM SQ	8
073069	HEAT SHRINKABLE SLEEVING 9.5MM BORE (RS398-177)	1
078417	EXTENDED HEX NUT M8	1
078773	OUTER FLANGE HOSE REEL (POWDER COAT)	1
079245	FLANGE ADAPTOR EXHAUST DTB500	1
079275	EXHAUST STUB KUBOTA 1803	1
081159	COUPLING KFG20 KNOTT 2000KG	1
081217	BRAKE CABLE 830/1040MM	2
081218	COMPENSATOR KIT (EQUALISER) - DTB500 SINGLE AXLE	1
081221	WHEEL AND TYRE 18570R13 TO SUIT DTB500/DTK500	2
081222	AXLE DTB500 1800KG BRAKE 250/40	1
082133	RAINFLAP DTB500	2
082137	JOCKEY WHEEL TO SUIT KFG20 DTB 500	1
082143	NUMBER PLATE MOUNTING BRACKET	1
082160	CANOPY PLASTIC DTK TRAILER 500 2019	1
082161	LOOSE WHEEL NUT INDICATORS 27MM (PACK 100)	10
085263	HYDRAULIC TANK DTB500	1
085341	TANK FUEL PLASTIC DTB500 MK2 40L	1
105204	BRACKET FOR HYD SELECTOR HV39 (POWDER COAT)	1
7002259	GUIDE HOSE FEED ASSY DTK	1
A030376	LID, SCREW INSPECTION COVER(6)BLACK.	1
A041024	SCREW CAPSCREW M10 X 50MM LONG SOCKET HD	2
A060574	FITTING TEE 1 1/4" BSP FEMALE UPVC	1
N01241	BARREL NIPPLE 1 1/4 BSP GALV	1

N01282	ELBOW 1 1/4 BSP MXF MALLEABLE GALV	1
N01496	ELBOW 1/2-1/2 BSP Mx F 90 COMPACT FORGED 415BAR	2
N02230	ADAPTOR 1/2" BSPM X 1/8" BSPM ZN	1
N05105	LINE STRAINER 1 1/4" (HYPRO)	1
N05114	SIGHT GLASS 10"	2
N05116	SIGHT LEVEL GAUGE 5116/7	1
N05798	HYDRAULIC FILTER (U.C.C. MX1518.102) RETURN FILTER	1
N10001	BATTERY RETAINING BRACKET	1

# 11. Service Documents

## 11.1. Service Checklist

SERVICE CHECK LIST														
Serial Number -										Sht 1 of 2				
Unit Number -														
Date -					Engineer -									
Hours Run -					ESR -									
I - Intermediate service			Y - Yearly service			R - Customer request								
Engine			Hydraulics			Water tank								
	I	Y	R		I	Y	R		I	Y	R			
1	Check oil level				34	Check oil level				63	Clean water filter			
2	Change oil				35	Change oil				64	Change water filter			
3	Change oil filter				36	Change filter				65	Check hoses & fittings			
4	Clean air filter				37	Inspect hoses				66	Check tank security			
5	Change air filter				38	Inspect reel				67	Check tank integrity			
6	Change fuel filter				39	Grease reel bearings				68	Check A/Freeze			
7	Clean water trap				40	Check reel mountings				69	Check inlet ball valve			
8	Check coolant level & A/F mix				41	Check operation				OMO Foot pedal				
9	Inspect radiator				42	Check for leaks						I	Y	R
10	Inspect hoses				Electrics/Controls					70	Check cable & plugs			
11	Check fan belt						I	Y	R	71	Test operation			
12	Check engine mounts				43	Check battery				72	Check safety button			
13	Check exhaust				44	Check/grease terminals				Pressure Hose				
14	Check throttle cable				45	Check charge system						I	Y	R
15	Check for leaks				46	Check wiring connections				73	Check for wear / damage			
Gearbox					47	Test/check operations				74	cuts / tears			
16	Check oil level				48	Test remote control unit				75	Brading showing			
17	Change oil				Vanpack frame					76	Any joins in single length			
18	Check for leaks						I	Y	R	77	Fittings in good order			
					49	Check for cracks/damage				78	Leader hose satisfactory			
					50	Check fixing bolts & brackets				Hot Wash				
Pump					51	Check safety straps						I	Y	R
					Trailer					79	Check fuel pump pressure			
20	Check valves (Inlet/delivery)						I	Y	R	80	Clean fuel filter			
21	Replace valves (Inlet/delivery)				52	Check for cracks/damage				81	Check swirl plate adjustment			
22	Check diaphragms				53	Check wheels/tyres/pressure				82	Check electrode gap			
23	Replace diaphragms				54	Check brake operation				83	Check air flow			
24	Change oil				55	Check lights/reflectors				84	Check thermostat operation			
25	Check hoses/fittings				56	Check tow hitch/lubricate				85	Check low water level switch			
26	Check working pressure				57	Check safety cable				86	Check unloader valve			
27	Check working temp				58	Check jockey wheel condition				87	Check burner is running clean			
28	Check smooth running				Gun & Lance					Remote Control				
29	Change Burst Disc (Must be changed every 6 months)						I	Y	R			I	Y	R
30	Set Safety Relief Valve (Must be set by manufacturer/authorised agent and reset/certificated every six months)				59	Check for leaks on pressure				88	Check handset operation			
30	Check main pressure gauge				60	Check for damage				89	Check Antenna			
31	Check burst disc fitted				61	Check operation				Other				
32	Check jump jet operational				62	Check jets are correct						I	Y	R
33	Pressure gauge reading correctly									90	Test emergency stop button			
I	Intermediate Service									91	Check safety decals visible			
Y	Yearly Service									92	Check ID plate condition			
R	At Request of Customer									93	Clean & tidy appearance			
NA - Not applicable, A - Adjusted, ✓ - Satisfactory, R - Repair required, O - Observation										FLOW 0321 Iss 3				
Note - If 'Adjusted' or 'Repair required' please describe issue on sht 2														

## 11.2. Service Logbook

Flowplant Unit Log Book		
Serial Number -		
Unit Number -		
Date of Manufacture -		Sht 1 of 2
Date .....	Official Flowplant Stamp and Signature	<div style="border: 2px solid red; width: 100px; height: 50px; margin: 0 auto;"></div>
Engineer .....		
Type of Service .....	Please state if other Service provider used .....	
Date .....	Official Flowplant Stamp and Signature	<div style="border: 2px solid red; width: 100px; height: 50px; margin: 0 auto;"></div>
Engineer .....		
Type of Service .....	Please state if other Service provider used .....	
Date .....	Official Flowplant Stamp and Signature	<div style="border: 2px solid red; width: 100px; height: 50px; margin: 0 auto;"></div>
Engineer .....		
Type of Service .....	Please state if other Service provider used .....	
Date .....	Official Flowplant Stamp and Signature	<div style="border: 2px solid red; width: 100px; height: 50px; margin: 0 auto;"></div>
Engineer .....		
Type of Service .....	Please state if other Service provider used .....	
Date .....	Official Flowplant Stamp and Signature	<div style="border: 2px solid red; width: 100px; height: 50px; margin: 0 auto;"></div>
Engineer .....		
Type of Service .....	Please state if other Service provider used .....	
Date .....	Official Flowplant Stamp and Signature	<div style="border: 2px solid red; width: 100px; height: 50px; margin: 0 auto;"></div>
Engineer .....		
Type of Service .....	Please state if other Service provider used .....	
Date .....	Official Flowplant Stamp and Signature	<div style="border: 2px solid red; width: 100px; height: 50px; margin: 0 auto;"></div>
Engineer .....		
Type of Service .....	Please state if other Service provider used .....	
Type of service - Intermediate, Yearly		FLOW 0322 Iss 1

Flowplant Unit Log Book		
Serial Number -		
Unit Number -		
Date of Manufacture -		Sht 2 of 2
Date .....	Official Flowplant Stamp and Signature	<div style="border: 2px solid red; width: 100px; height: 50px;"></div>
Engineer .....		
Type of Service .....	Please state if other Service provider used .....	
Date .....	Official Flowplant Stamp and Signature	<div style="border: 2px solid red; width: 100px; height: 50px;"></div>
Engineer .....		
Type of Service .....	Please state if other Service provider used .....	
Date .....	Official Flowplant Stamp and Signature	<div style="border: 2px solid red; width: 100px; height: 50px;"></div>
Engineer .....		
Type of Service .....	Please state if other Service provider used .....	
Date .....	Official Flowplant Stamp and Signature	<div style="border: 2px solid red; width: 100px; height: 50px;"></div>
Engineer .....		
Type of Service .....	Please state if other Service provider used .....	
Date .....	Official Flowplant Stamp and Signature	<div style="border: 2px solid red; width: 100px; height: 50px;"></div>
Engineer .....		
Type of Service .....	Please state if other Service provider used .....	
Date .....	Official Flowplant Stamp and Signature	<div style="border: 2px solid red; width: 100px; height: 50px;"></div>
Engineer .....		
Type of Service .....	Please state if other Service provider used .....	
Date .....	Official Flowplant Stamp and Signature	<div style="border: 2px solid red; width: 100px; height: 50px;"></div>
Engineer .....		
Type of Service .....	Please state if other Service provider used .....	
Type of service - Intermediate, Yearly		FLOW 0322 Iss 1



## 12. Warranty

### 12.1. Warranty of new products:

Equipment manufactured and supplied by Flowplant is warranted to be free from defects in materials and workmanship.

The warranty includes both parts and labour necessary to correct any such defects.

The warranty period for new products is twelve months from date of despatch from our factory.

We shall repair or, at our discretion, replace free of charge any product, part(s) or component(s) manufactured by Flowplant which fail due to faulty manufacture or material within the warranty period.

### 12.2. Warranty of spare parts:

The warranty for new spare parts is six months from date of despatch on materials and workmanship.

The warranty for reconditioned spare parts is 90 days from date of despatch on materials and workmanship.

Provided always that:

- They are returned to Flowplant for inspection (carriage paid), along with a copy of the original part(s) sale invoice (where necessary); and
- All terms agreed by Flowplant for payment of such goods have been complied with; and
- If a defect/failure is discovered before the expiration of the warranty, notification must be given to the Flowplant service department immediately
- Any claim hereunder is made within 30 days of the date of discovery of the defect/failure.

Provision of this warranty shall not apply to any Flowplant product which has been:

- Used for a purpose for which it is not designed for; or
- Applied to a use which has not been approved by Flowplant; or
- Subject to misuse, negligence, lack of maintenance or accident; or

- Repaired or altered in any way so as, in the judgement of Flowplant, to adversely affect its performance and reliability

### **12.3. Limitations of warranty:**

The new product and spare parts warranty is limited to defects in material or workmanship of the product. It does not cover loss of time, inconvenience, property damage or any consequential damages. Repair or replacement of the product is your exclusive remedy.

Our liability under this clause shall be in lieu and to this exclusion of any warranty or conditions implied or expressed by law as to the quality or fitness for purpose of any goods supplied hereunder PROVIDED THAT nothing in this clause shall operate so as to exclude liability for death or personal injury arising from the negligence of the company or its employees.

Our obligations as aforesaid shall constitute the full extent of our liability in respect of any loss or damage sustained by the purchaser whether caused by any breach of this contract or by our negligence or otherwise and we shall not be liable to make good or pay for loss of use of the goods, loss of revenue, loss of profit or goodwill or any direct or consequential losses howsoever caused and the purchaser undertakes to indemnify us against any such claims against us by third parties.

In order to comply with the provision of the Health and Safety at work etc. Act 1974 in respect of articles manufactured, supplied or installed for use at work we test all our products before they leave our factory and supply them with adequate instructions for their proper use. Further copies of these instructions are available from us upon request.



*Page left intentionally blank*